

WIESE Continuous Bucket Conveyor "SEB"

Dimensions in [mm]

Bucket Volume at water level 100% [l]

type	A	B	C	D	E	F [min.]	H [min.]	I [min.]	K [min.]	P	U	V	Bucket-pitch	Bucket-volume
SEB 03	338	260	350	80	150	530	885	550	645	260	121	100	99	0,3
SEB 05	478	400	350	200	150	530	885	550	645	260	253	100	99	0,7
SEB 1/05	458	380	460	150	250	820	1.220	750	1.015	410	212	80	165	1,7
SEB 1	598	500	500	150	250	970	1.900	840	1.255	410	212	100	165	1,7
SEB 2/05	518	440	550	200	250	1.100	1.740	940	1.365	550	267	80	198	3,0
SEB 2	668	570	600	200	250	1.150	1.900	940	1.415	550	267	100	198	3,0
SEB 4	718	620	600	300	250	1.150	1.900	1.140	1.615	550	392	100	198	5,1
SEB 5	818	700	750	280	400	1.325	2.250	1.290	1.925	750	375	150	215	6,5
SEB 10	1.118	1.000	770	450	400	1.350	2.250	1.290	1.925	750	600	150	215	10

Subject to change (without notice)

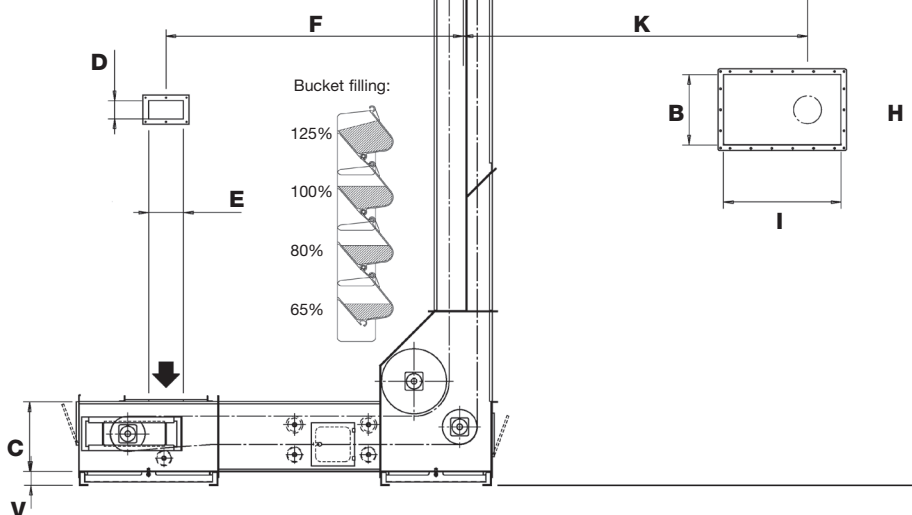
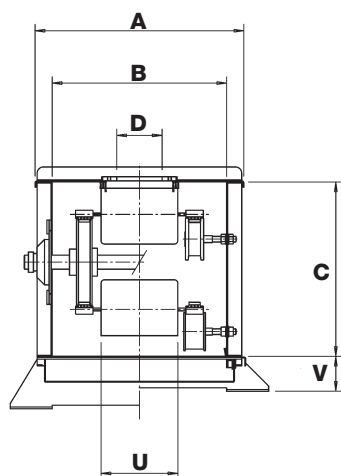
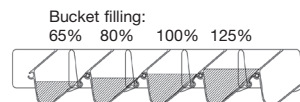
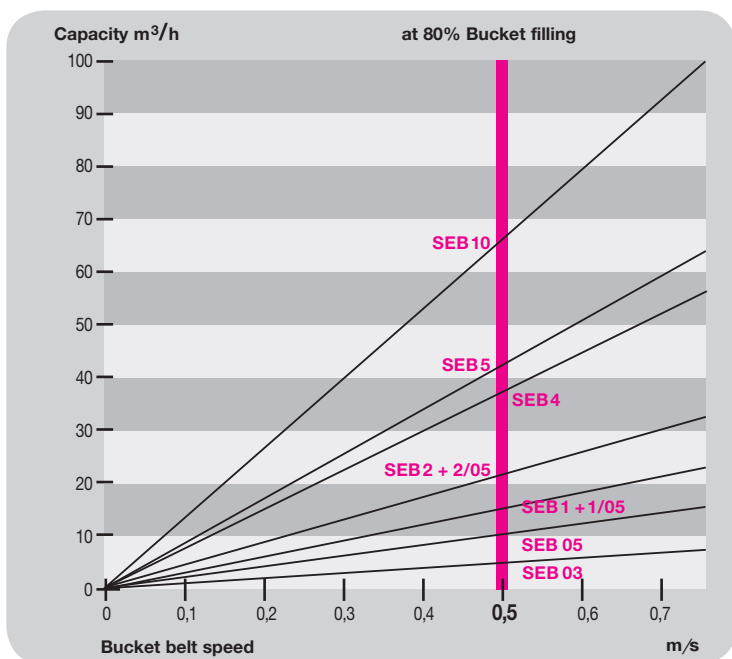

WIESE Fördererelemente GmbH

Am Mühlenfelde 1 · D-30938 Burgwedel · Phone +49(0)5135/188-0 · Fax +49(0)5135/188-30
 info@wiese-germany.com · www.wiese-germany.com

WIESE Pendulum Bucket Conveyor "P"

Dimensions in [mm]

Bucket Volume at water level 100% [l]

type	A	B	C ₁	C ₂	D	E	F [min.]	H [min.]	I	K [min.]	L [min.]	P	U	V	Bucket-pitch	Bucket-volume
P5	518	420	435	450	160	250	685	970	500	720	620	480	195	100	165	1,6
P10	668	570	435	450	310	250	685	970	500	720	620	480	345	100	165	2,8
P20	798	700	535	550	440	250	820	1.220	600	855	720	530	476	100	198	5,8
P30	918	820	620	700	400	400	1.300	2.200	880	1.525	1.050	700	480	200	258	12,1
P40	1.218	1.120	620	700	700	400	1.300	2.200	880	1.525	1.050	700	780	200	258	19,5

Subject to change (without notice)

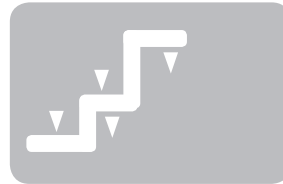
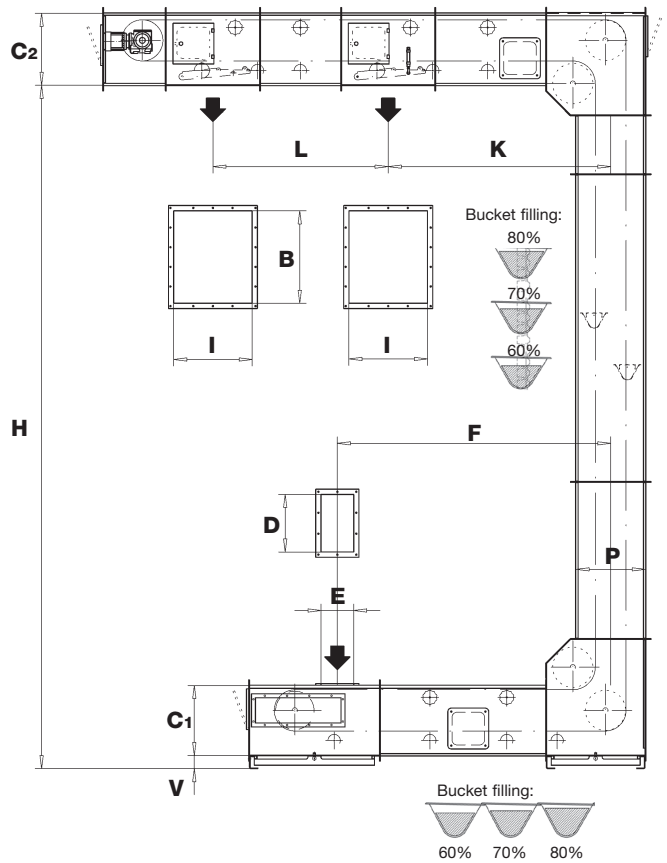
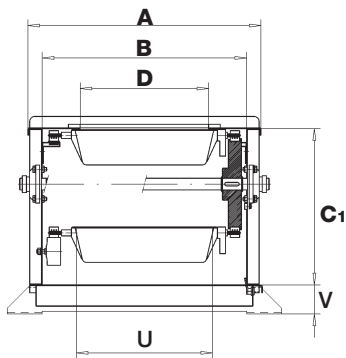
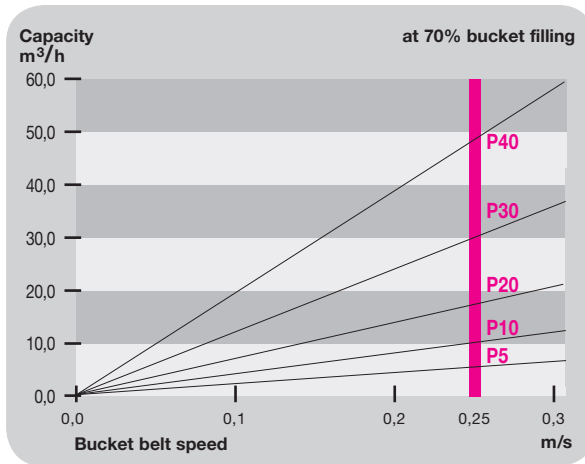

WIESE Fördererelemente GmbH

Am Mühlenfelde 1 · D-30938 Burgwedel · Phone +49(0)5135/188-0 · Fax +49(0)5135/188-30
 info@wiese-germany.com · www.wiese-germany.com