

WIESE Pendulum Bucket Conveyor "P"

Dimensions in [mm]

Bucket Volume at water level 100% [l]

type	A	B	C ₁	C ₂	D	E	F [min.]	H [min.]	I	K [min.]	L [min.]	P	U	V	Bucket-pitch	Bucket-volume
P5	518	420	435	450	160	250	685	970	500	720	620	480	195	100	165	1,6
P10	668	570	435	450	310	250	685	970	500	720	620	480	345	100	165	2,8
P20	798	700	535	550	440	250	820	1.220	600	855	720	530	476	100	198	5,8
P30	918	820	620	700	400	400	1.300	2.200	880	1.525	1.050	730	480	200	258	12,1
P40	1.218	1.120	620	700	700	400	1.300	2.200	880	1.525	1.050	730	780	200	258	19,5

Subject to change (without notice)

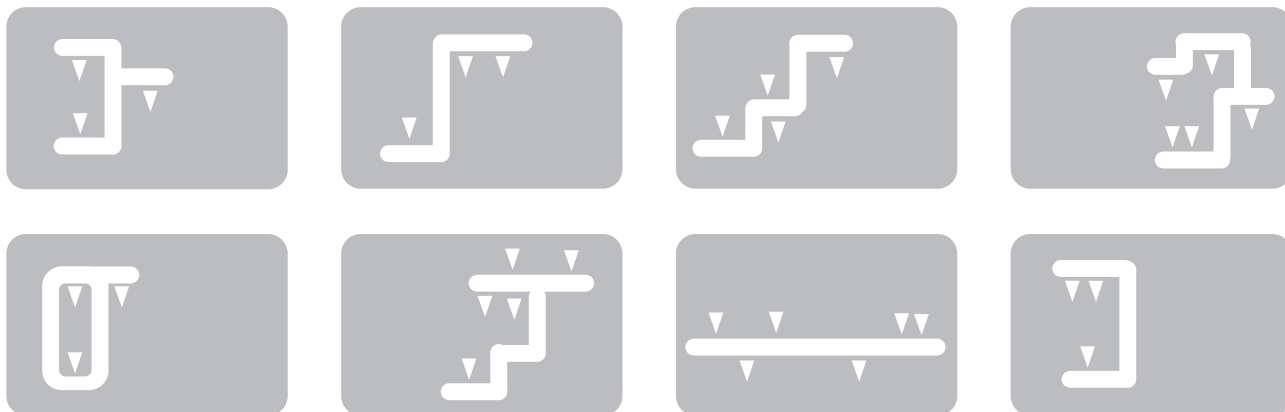
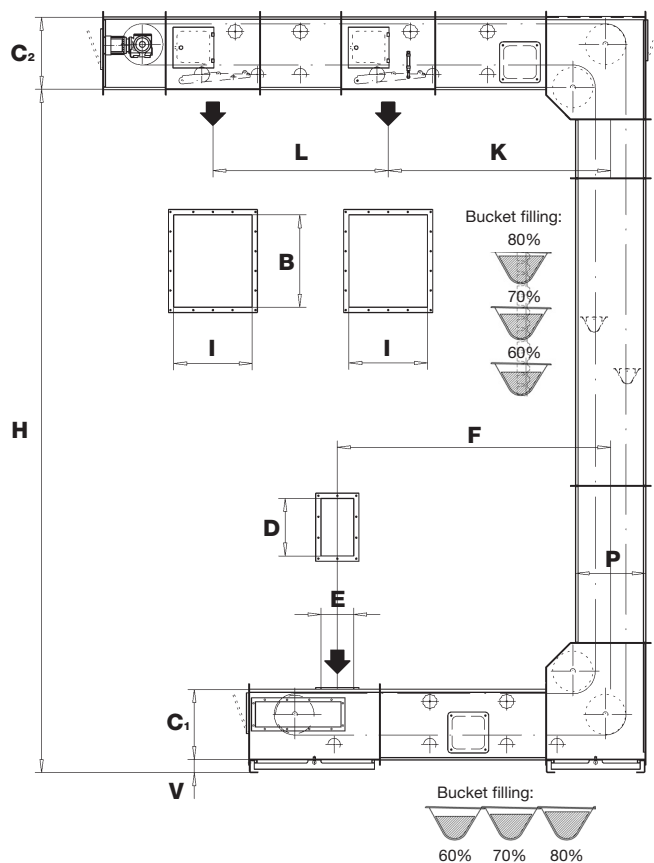
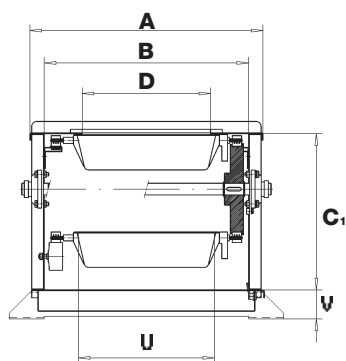
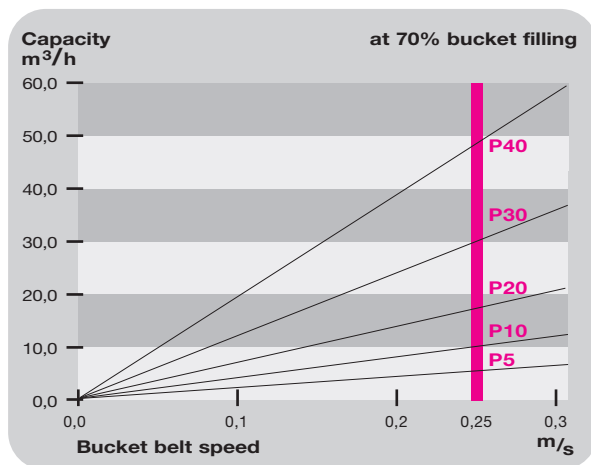

WIESE Fördererlemente GmbH

Am Mühlenfelde 1 · D-30938 Burgwedel · Phone +49(0)5135/188-0 · Fax +49(0)5135/188-30
 info@wiese-germany.com · www.wiese-germany.com